

MODERN LINEAR

MOUNTING AND ADJUSTMENT

The fixed bushing should be used to carry the heaviest loading. Preload the adjustable bushing so that the roller can just be turned by hand. Over-tightening the preload will cause premature wear of the components.

TRACK & WHEEL SIZE	XI (in.)
1	0.874
2	1.374
3	2
4	2.624
4XL	3.124

LUBRICATION / MATERIALS / SYSTEM LIFE

The guide rollers are grease lubricated and will not require any additional lube. The track should be lubricated for optimum performance and service life. Suggested lubricants are Mobil Vactra # 2 Way Oil, or Mobil Polyrex EP 2 Extreme Pressure Grease.

- Lubricated wheel/track interface refers to the presence of lubrication.
- Ratings are based on 2 million inches of travel life.
- Ratings have been confirmed by independent lab tests.

TRACK DERATE FACTORS		
	LUBRICATION	NO LUBRICATION
HARDENED TRACK	1.00	.50
UNHARDENED TRACK	.75	.25

SUGGESTED FASTENERS

BUSHINGS	
SIZE	ENGLISH
B-1	#6
B-2	1/4"
B-3	5/16"
B-4	3/8"
B-4XL	5/8"

TRACK		
SIZE	ENGLISH	METRIC
T-1	#6	M3
T-2	#10	M6
T-3	1/4"	M6
T-4	5/16"	M6

CENTER DISTANCE FORMULA

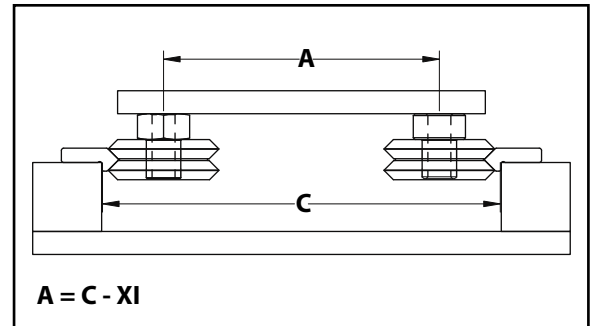
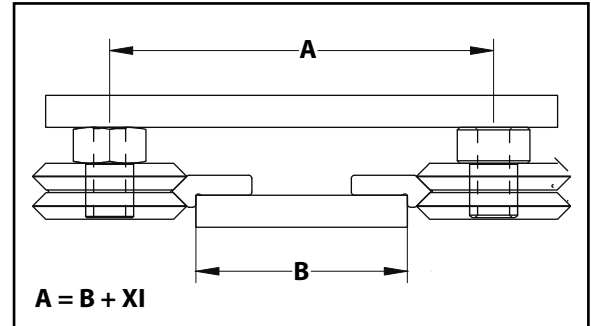

ROLLER / BUSHING ASSEMBLY

Use SAE series N flat washers and lock washers to secure the roller bushing assemblies.

