

MODERN LINEAR

DOUBLE TRACK LINEAR GUIDE

- Compact overall package
- Standard and custom lengths
- Easy to install

NEW

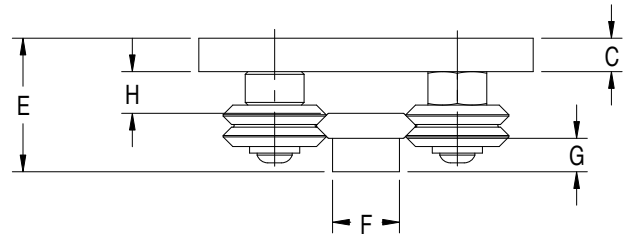
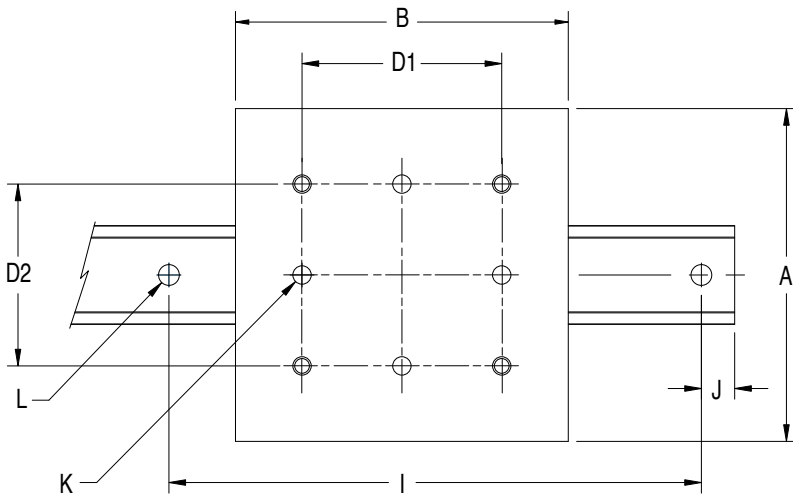

DIMENSIONS (INCHES)

SIZE	A	B	C	D1	D2	E	F	G	H	I	J	K	L	CARRIAGE	RAIL
DT-1	2.500	2.500	0.250	1.500	1.366	0.999	0.500	0.250	0.312	4.000	1.500	#6-32 UNC	0.156	DTC-1	DTR-1
DT-2	4.000	4.000	0.500	2.500	1.993	1.438	0.750	0.500	0.375	6.000	1.500	1/4-20 UNC	0.219	DTC-2	DTR-2
DT-3	5.000	5.000	0.500	3.000	2.738	1.750	0.750	0.500	0.500	8.000	1.500	5/16-18 UNC	0.313	DTC-3	DTR-3
DT-4	6.000	6.000	0.625	3.500	3.483	2.156	1.000	0.625	0.594	8.000	1.500	3/8-16 UNC	0.375	DTC-4	DTR-4

LOAD CAPACITY (LBS.)

SIZE	LBS.		FT-LBS.	
	LA	LR	MA	MR
DT-1	228	268	125	118
DT-2	560	644	505	434
DT-3	1528	1382	1776	1676
DT-4	3596	2116	5106	5091

Working load capacities reflect lubricated wheel/track interface.

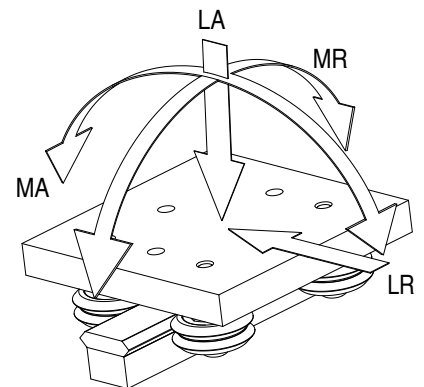

ORDERING

LINEAR GUIDE	DT-__	X __ (INCHES)
CARRIAGE	DTC-__	
RAIL	DTR-__	X __ *

* STANDARD LENGTHS
12,24,36,48 INCHES
MAX. LENGTH 48 INCHES